

# CozIR<sup>®</sup>-LP CO<sub>2</sub> Sensor

📈 Measurement range: 0-2000ppm; 0-5000ppm; 0-1%

🔋 Battery applications ⚡ V. low power

📏 Miniature ⌚ Long lifetime

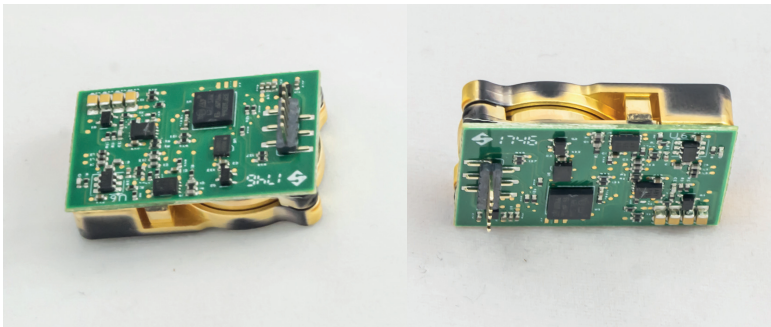

## Overview

CozIR®-LP is a very low power CO2 sensor - the lowest power and longest life NDIR CO2 sensor available today.

It's world-leading low power consumption makes it ideal for battery powered systems, including portable, wearable and self-powered applications.

Designed for measuring low levels of CO2, this miniature, lightweight sensor offers easy integration into gas monitoring and detection systems.

CozIR®-LP is built on our unique patented LED technology platform and optical designs. It's this solid-state technology that enables best-in-class power consumption, lifetime and durability.

## Applications

CozIR®-LP is designed for low concentration CO2 environments, with measurement ranges from 0-2000ppm, 0-5000ppm and 0-1%.

The sensor is suitable for battery applications, where low power consumption is required. This includes IoT applications, such as 'smart homes' and 'smart cities'.

Examples of markets where CozIR®-LP CO2 sensors are being successfully used:

- Indoor air quality (IAQ)
- Building control
- Food packaging
- Automotive
- Safety
- HVAC
- Horticulture & agriculture
- Instrumentation
- Aerospace

## Benefits

- Ideal for very low power and battery applications
- Up to 50X lower power than typical NDIR CO2 sensors
- Low maintenance
- Fits neatly inside compact instruments
- Suitable for wireless, portable, wearable and self-powered systems
- Integrates with wireless IoT networks such as ZigBee, Wifi, LoRa, Bluetooth, SigFox and EnOcean
- Supports energy-efficient 'smart homes'

## Features

- Very low power/energy consumption - 3mW
- Measures up to 1% CO2 concentration
- >15 years lifetime
- Miniature format
- Solid-state - no moving parts, no heated filaments
- Vibration and shock resistant
- Non-heating
- Self-calibrating<sup>1</sup>
- Digital (UART) output
- RoHS compliant
- Manufactured in the UK



## General performance

<b>Start-up time<sup>2</sup></b>	1.2 secs
<b>Operating conditions- Temperature</b>	0°C to 50°C (standard) -25°C to 55°C (extended range)
<b>Operating conditions- Humidity<sup>3</sup></b>	0 to 95% RH, non-condensing
<b>Recommended storage</b>	-30°C to +70°C

## CO<sub>2</sub> measurement

<b>Sensing method</b>	Solid-state Non-Dispersive InfraRed (NDIR) absorption Patented solid-state LED and detector Patented gold-plated optics
<b>Sample method</b>	Diffusion
<b>Measurement range</b>	0-2000ppm 0-5000ppm 0-1%
<b>Accuracy<sup>4</sup></b>	+/(45ppm+3% of reading)
<b>Calibration</b>	Autocalibration <sup>5</sup>
<b>Pressure dependence<sup>6</sup></b>	0.13% of reading per mbar in normal atmospheric conditions
<b>Operating pressure range<sup>7</sup></b>	500mbar – 10 bar
<b>Response time, T90<sup>8</sup></b>	30 secs - 3 mins

## Electrical

<b>Power input<sup>9</sup></b>	3.25 to 5.5V. (3.3V recommended) Peak Current 33mA Average Current <1mA
<b>Power consumption<sup>9</sup></b>	3.0mW
<b>Connector<sup>10</sup></b>	6-way 1.27mm header
<b>Communication</b>	UART

## Dimensions/weight

<b>Length</b>	31mm
<b>Width</b>	19.5mm
<b>Height<sup>11</sup></b>	8mm
<b>Weight</b>	5g

## Warranty

<b>Sensor warranty<sup>12</sup></b>	1 year
-------------------------------------	--------

**1** Autocalibration is enabled by default on the COZIR-LP CO2 sensor. For correct operation, the sensor must experience a CO2 concentration close to fresh air during a 24 hour period. For further details, please request our application note on Autocalibration.

**2** Time to a valid reading is determined by digital filter setting. Typically 4-8 seconds.

**3** For extended operation in high temperature and humidity environments, contact GSS

**4** All measurements are at NTP unless stated otherwise.

**5** Enabled by default. For correct operation, the sensor must experience CO2 concentrations close to fresh air at some time in an 8 day period. For further details, please contact us to request our application note on Autocalibration.

**6** Calibrated for 1013mbar. GSS can supply advanced pressure correction advice when operating outside normal atmospheric conditions.

**7** External pressure calibration required.

**8** Response time to a step change in gas level is dependent on application/filter/flow rate/diffusion.

**9** Power measurements for standard CO2 sensor with 2 readings per second.

**10** part number BD021-06A-K1-0350-0150-0550-L, example mating parts BD080-06, BD0074-06

**11** Excludes height of connector pins.

**12** Gas Sensing Solutions Ltd (GSS Ltd) offers a limited one (1) year manufacturer's warranty on its products commencing from the date of original purchase. The warranty is limited to defects in materials and workmanship and does not cover damage or abnormal wear and tear resulting from abuse, misuse, or accidental damage. The warranty excludes operational damage due to exposure to blasts or other threats such as excessive abrasion or flames. Unauthorized repairs or alterations void the product warranty. GSS Ltd cannot and does not assume liability for defective products not manufactured or supplied by it even though such be used in conjunction with products manufactured by GSS Ltd.

# Technical drawings

THIS INFORMATION SUPPLIED BY GSS IS BELIEVED TO BE ACCURATE AND RELIABLE.  
HOWEVER NO RESPONSIBILITY IS ASSUMED BY GSS LTD FOR ITS USE.

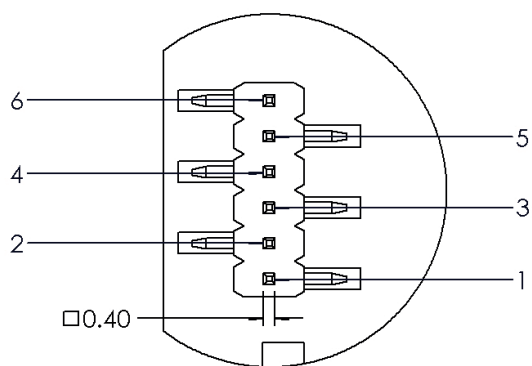
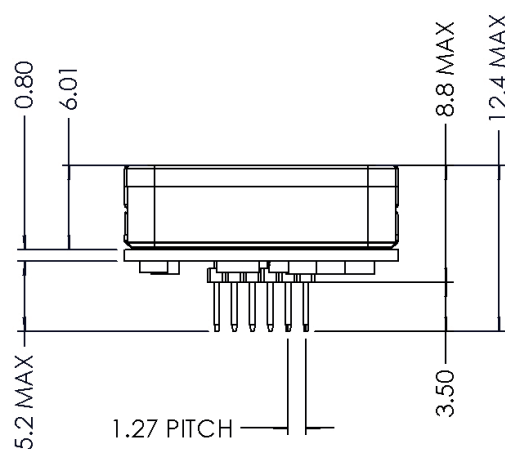
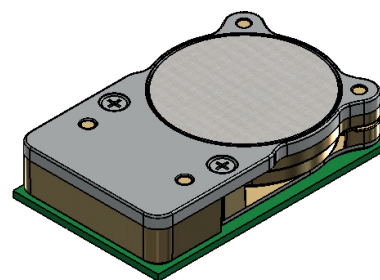
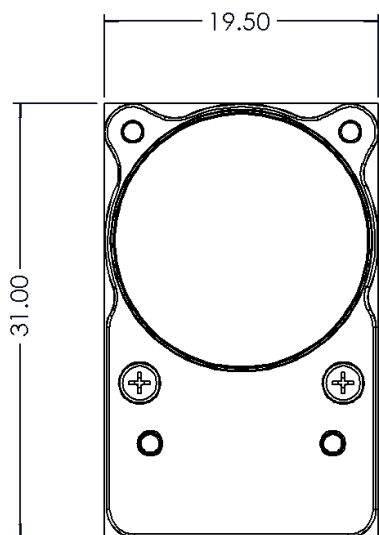

DETAIL A  
SCALE 4 : 1

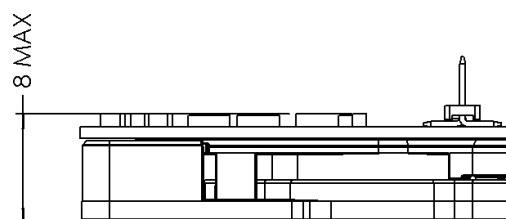

FUNCTION	PIN #
GND	1
Vsupply	2
Rx IN	3
Tx OUT	4
N/C	5
N/C	6

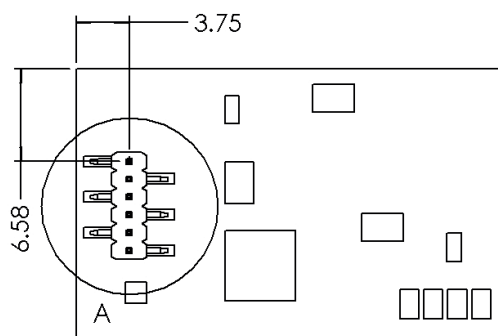

## Put it to the test

Our evaluation kit contains everything you need to test the sensor for your project requirements. The USB cable allows you to easily connect the CozIR®-LP sensor to your PC, for real-time CO2 readings.

- CO2 sensor (including adapter if specified)
- USB connecting cable
- Evaluation guide on USB stick

Please visit our website to [request a quote](#) for an evaluation kit.

## Technical support

The GSS team are specialists in CO2 sensor design, manufacture and customisation. We can advise how best to integrate our award-winning sensors into your product or process. Whether it's a fixed unit, portable instrument, wearable device, or energy harvester, our engineering team have the experience to help bring your project to life.

For more information about GSS and our technology, please visit our [About](#) page.

## Custom sensors

If you need the sensor to be altered to your specific requirements, our engineering team can develop a custom solution for you. Please [contact us](#) to discuss your project requirements with our engineering department.

This documentation is provided on an as-is basis and no warranty as to its suitability or accuracy for any particular purpose is either made or implied. Gas Sensing Solutions Ltd will not accept any claim for damages howsoever arising as a result of use or failure of this information. Your statutory rights are not affected. This information is not intended for use in any medical appliance, device or system in which the failure of the product might reasonably be expected to result in personal injury. As GSS is committed to continuous improvement, this document provides information that may be subject to change without notice.