

# Product Specification

<b>Product:</b>	<b>Laser Partical Sensor</b>
<b>Product model:</b>	PMS5003IB
<b>Specification No.:</b>	PTQ3011-2018
<b>Version:</b>	V1.0

Writer	Verifier	Standardization	Approver
Zhao Zhendong	Zheng Haoxin	Lu Lili	Zhou Yong
2019-2-20	2019-2-20	2019-2-20	2019-2-20

ADD: 6/f, Building 9, Yuxi Road No. 9, Houshayu, Shunyi district, Beijing, P. R. China

TEL: 010-64731933

FAX: 010-64737980

URL: [www.plantower.com](http://www.plantower.com)

Email: [info@plantower.com](mailto:info@plantower.com)

<b>PLANTOWER</b> 攀藤科技	<b>PMS5003IB Datasheet</b>	DOCUMENT No	PTQ3011-2018
		Version	V1.0
		Date	2019-2-20

## Catalogue

Log Page .....	2
1. Main characteristics .....	3
2. Overview .....	3
3. Working principle .....	4
4. Technical Index .....	4
5. Pin Definition .....	6
6. Output result.....	7
7. Typical Circuit .....	7
8. Typical Output Characteristic.....	8
9. Endurance Characteristics.....	10
10. Part Number Definition .....	12
11. Physical Size .....	13
12. Installation Attentions .....	14
13. Other Attentions.....	14
14. Appendix A: PMS5103I Protocol.....	15

<b>PLANTOWER</b> 攀 藤 科 技	<b>PMS5003IB Datasheet</b>	DOCUMENT No	PTQ3011-2018
		Version	V1.0
		Date	2019-2-20

### Log Page

Version	Note	Date	Writer
V1.0	Newly-built	2019.2.20	Lu Lili

<b>PLANTOWER</b> 攀藤科技	<b>PMS5003IB Datasheet</b>	DOCUMENT No	PTQ3011-2018
		Version	V1.0
		Date	2019-2-20

## 1. Main characteristics

- ◆ Zero false alarm rate
- ◆ Real-time response
- ◆ Correct data
- ◆ Minimum distinguishable particle diameter :0.3 micrometer
- ◆ High anti-interference performance because of the patent structure of six sides shielding
- ◆ Optional direction of air inlet and outlet in order to adapt the different design



## 2. Overview

PMS5003IB is a kind of digital and universal particle concentration sensor, which can be used to obtain the number of suspended particles in the air, i.e. the concentration of particles, and output them in the form of digital interface. This sensor can be inserted into variable instruments related to the concentration of suspended particles in the air or other environmental improvement equipments to provide correct concentration data in time.

<b>PLANTOWER</b> 攀藤科技	<b>PMS5003IB Datasheet</b>	DOCUMENT No	PTQ3011-2018
		Version	V1.0
		Date	2019-2-20

### 3. Working principle

Laser scattering principle is used for such sensor, i.e. produce scattering by using laser to radiate suspending particles in the air, then collect scattering light in a certain degree, and finally obtain the curve of scattering light change with time. In the end, equivalent particle diameter and the number of particles with different diameter per unit volume can be calculated by microprocessor based on MIE theory. Please find the functional diagram of each part of sensor from Figure 1 as follows.

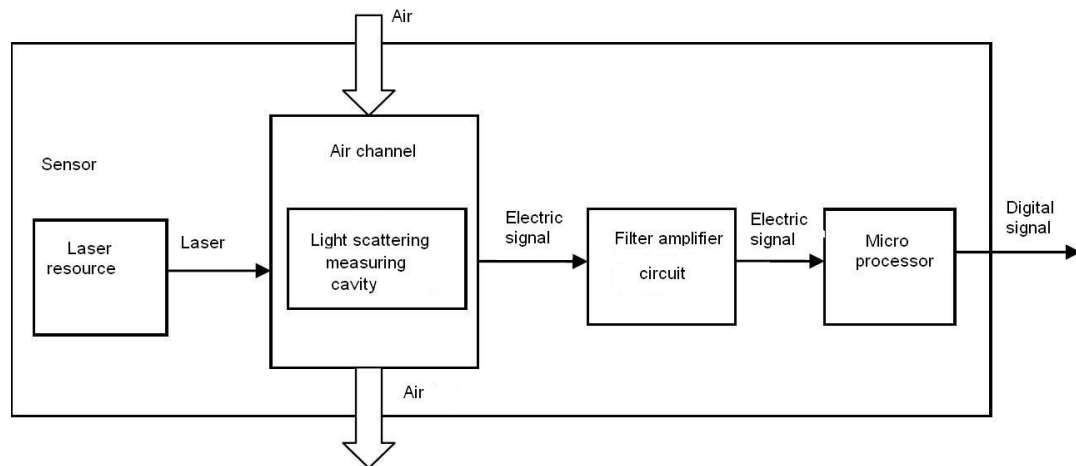

Figure 1 Functional block diagram of sensor

### 4. Technical Index

Parameter	Index	unit
Range of measurement	0.3~1.0; 1.0~2.5; 2.5~10	Micrometer ( $\mu\text{m}$ )
Counting Efficiency	50%@0.3 $\mu\text{m}$ 98%@ $\geq 0.5\mu\text{m}$	

<b>PLANTOWER</b> 攀藤科技	<b>PMS5003IB Datasheet</b>	DOCUMENT No	PTQ3011-2018
		Version	V1.0
		Date	2019-2-20

Effective Range (PM2.5 standard)	0~500	µg/m <sup>3</sup>
Maximum Range (PM2.5 standard)*	≥1000	µg/m <sup>3</sup>
Resolution	1	µg/m <sup>3</sup>
Maximum Consistency Error (PM1.0,PM2.5 standard data)*	±15%@100~500µg/m <sup>3</sup> ±15µg/m <sup>3</sup> @0~100µg/m <sup>3</sup>	
Maximum Consistency Error (PM10 standard data)*	±25%@100~500µg/m <sup>3</sup> ±25µg/m <sup>3</sup> @0~100µg/m <sup>3</sup>	
Standard Volume	0.1	Litre (L)
Single Response Time	<1	Second (s)
Total Response Time	≤10	Second (s)
DC Power Supply	Typ:5.0 Min:4.5 Max: 5.5	Volt (V)
Active Current	≤100	Milliamper (mA)

Parameter	Index	unit
Standby Current	≤1	Milliamper (mA)
Noise	≤29db @ 5cm	
FAN Coating	IP51	
Interface Level	L <0.8 @3.3 H >2.7@3.3	Volt (V)
Working Temperature Range	-10~+60	°C
Working Humidity Range	0~99%	
Storage Temperature Range	-40~+80	°C
MTTF*	≥3	Year (Y)
Physical Size	50x38x21	Millimeter (mm)

<b>PLANTOWER</b> 攀藤科技	<b>PMS5003IB Datasheet</b>	DOCUMENT No	PTQ3011-2018
		Version	V1.0
		Date	2019-2-20

Note 1: Maximum range means that the highest output value of the PM2.5 standard data is not less than 1000.

Note 2: "PM2.5 standard data" is the "data2" in the appendix. 20°C, 50%.

Note 3: MTTF ≥ 10 under 25°C, RH50%.

## 5. Pin Definition

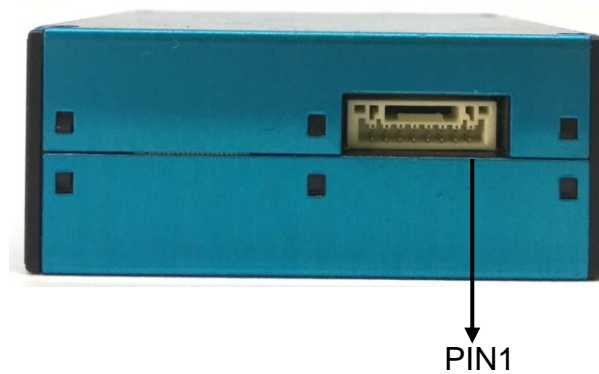

Figure 2 Connector Definition

Pin number	Pin name	Description
<b>PIN1</b>	VCC	Positive power 5V
<b>PIN2</b>	GND	Negative power
<b>PIN3</b>	SET	Set pin /TTL level@3.3V, <b>high level</b> or <b>suspending</b> is normal working status, while low level is sleeping mode. It should be not connecting or 10k Resister Pull up if no use.
<b>PIN4</b>	I2C_SCL	I2C Clock pin/TTL level@3.3V, 3~5K pull up Resister needed.
<b>PIN5</b>	I2C_SDA	I2C DATA pin/TTL level@3.3V, 3~5K pull up Resister needed.
<b>PIN6</b>	RESET	Module reset signal /TTL level@3.3V, low reset. It should be not connecting or 10k Resister Pull up if no use.
<b>PIN7/8</b>	NC	

<b>PLANTOWER</b> 攀藤科技	<b>PMS5003IB Datasheet</b>	DOCUMENT No	PTQ3011-2018
		Version	V1.0
		Date	2019-2-20

## 6. Output result

Mainly output as the quality and number of each particles with different size per unit volume, the unit volume of particle number is 0.1L and the unit of mass concentration is  $\mu\text{g}/\text{m}^3$ .

I2C Slave mode.

## 7. Typical Circuit

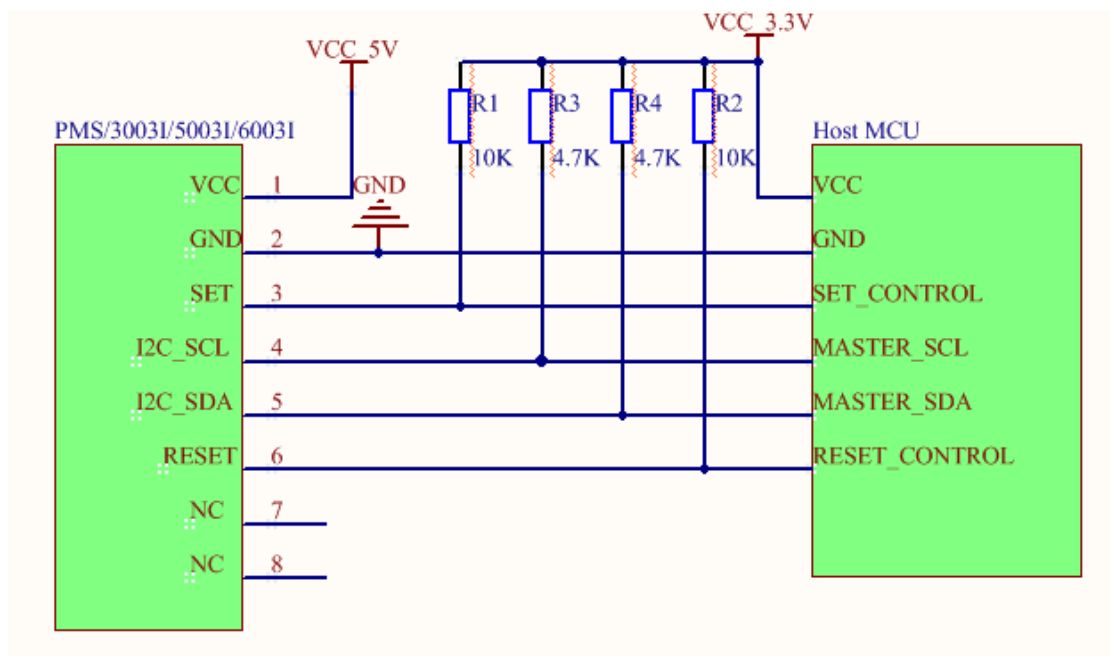

Figure 3 Typical Circuit

Note: Figure 3 is used in the case of controlling the SET and RESET pin(PIN 3 and PIN6)



<b>PLANTOWER</b> 攀藤科技	<b>PMS5003IB Datasheet</b>	DOCUMENT No	PTQ3011-2018
		Version	V1.0
		Date	2019-2-20

### 8. Typical Output Characteristic

Definition of axis Y: PM2.5 concentration, unit:  $\mu\text{g}/\text{m}^3$

Definition of axis X: number of samples, unit: time

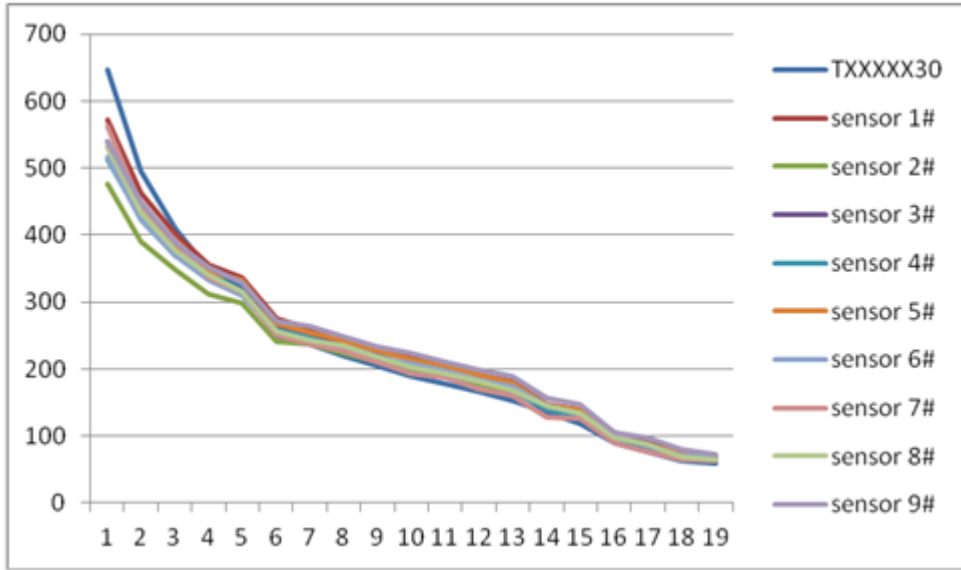

Figure 4-1 Consistency at 20°C

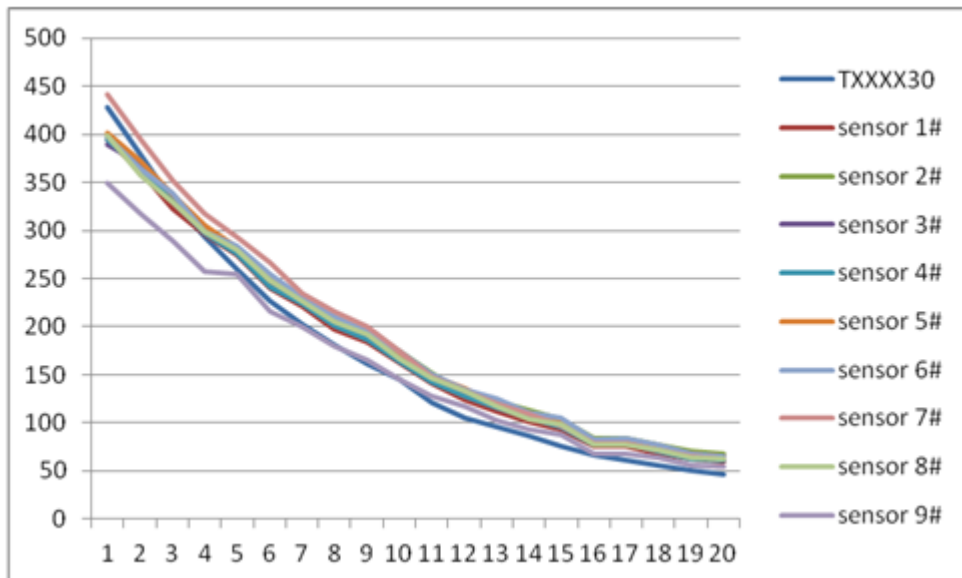

Figure 4-2 Consistency at 43°C

<b>PLANTOWER</b> 攀藤科技	<b>PMS5003IB Datasheet</b>	DOCUMENT No	PTQ3011-2018
		Version	V1.0
		Date	2019-2-20

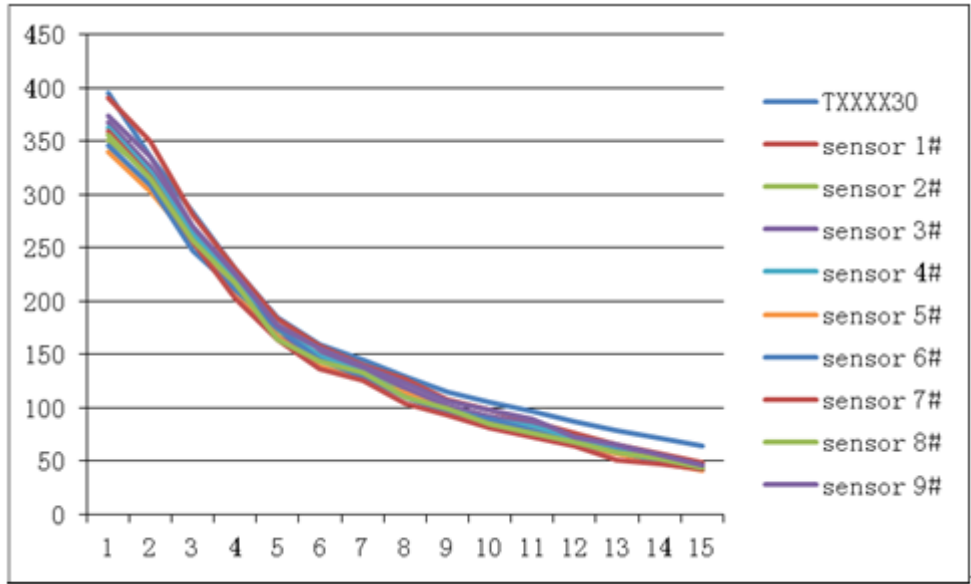

Figure 4-3 Consistency at -5°C

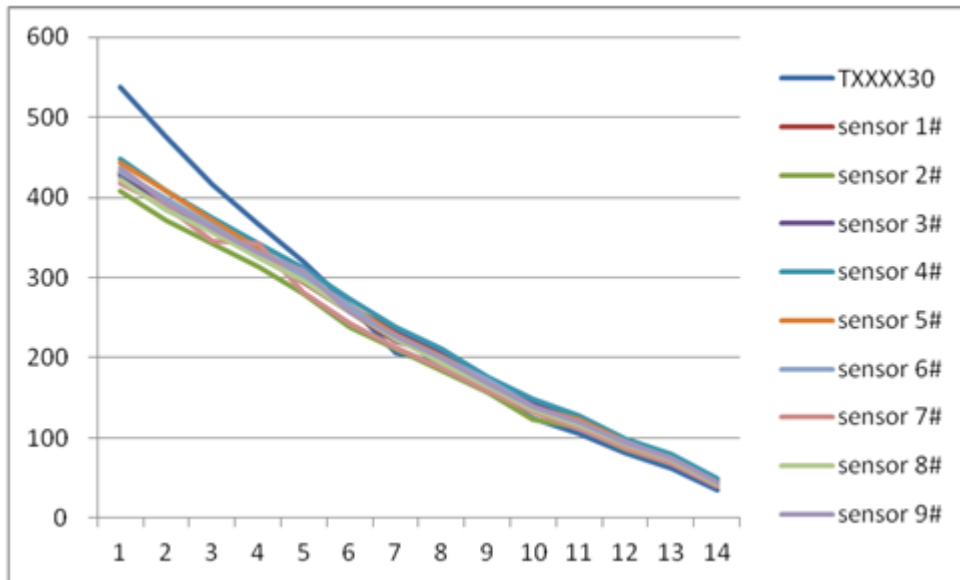

Figure 4-4 Consistency after 30 days running

<b>PLANTOWER</b> 攀藤科技	<b>PMS5003IB Datasheet</b>	DOCUMENT No	PTQ3011-2018
		Version	V1.0
		Date	2019-2-20

Relationship of Temperature and Consistency

Definition of axis Y: Maximum Error Modulus(%)

Definition of axis X: Temperature(°C)

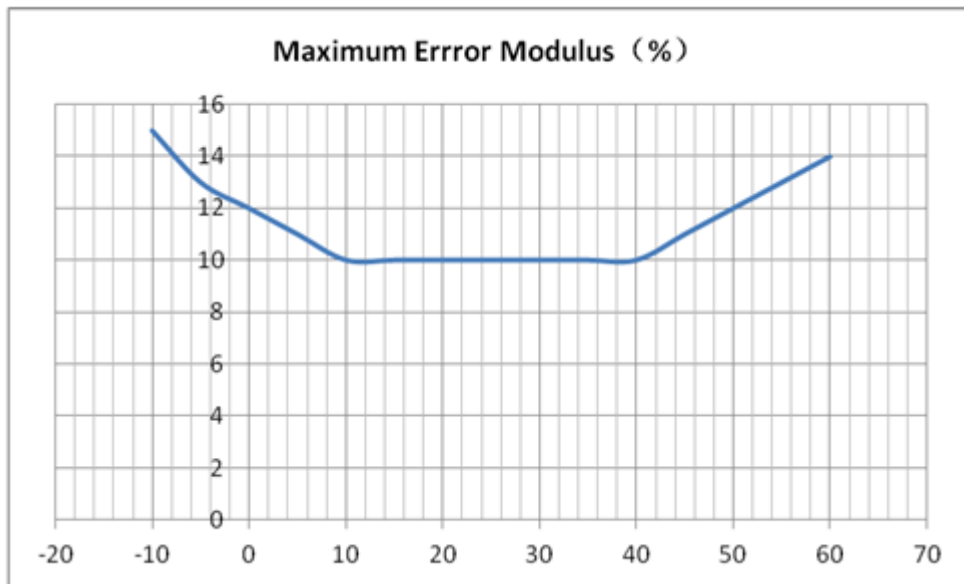

Figure 5 Consistency Vs Temperature

**9. Endurance Characteristics**

No	Item	Test Method	Characteristics	n C
1	Long Running	1. 10 m <sup>2</sup> closed Lab,, 20~25°C , humidity 30%~70%, particle generator and air cleaner 2. DC 5V power supply 3. Check consistency after 720 hours' running	10 samples during 0~500µg/m <sup>3</sup>  0~100µg/m <sup>3</sup> Maximum Error≤±15µg/m <sup>3</sup>	n=30 C=0
2	High Temperature Operation	1. 10 m <sup>2</sup> constant temperature Lab 2. 43°C , humidity 70%, 3. particle generator and air cleaner 4. DC 5V power supply 5. Check consistency	100~500µg/m <sup>3</sup> Maximum Error≤±15%	n=10 C=0
3	Cold Operation	1. 10 m <sup>2</sup> constant temperature Lab		n=10

<b>PLANTOWER</b> 攀藤科技	<b>PMS5003IB Datasheet</b>	DOCUMENT No	PTQ3011-2018
		Version	V1.0
		Date	2019-2-20

		2. -5℃, humidity 30%, 3. particle generator and air cleaner 4. DC 5V power supply 5. Check consistency	FAN does not screeched	C=0
4	Vibration	1. 10 m <sup>2</sup> closed Lab,, 20℃, humidity 50%, particle generator and air cleaner 2. DC 5V power supply and check consistency 3. Frequency: 50Hz。 4. acceleration: 9.8/ S <sup>2</sup> 。 5. Direction: X、Y、Z 6. Vibration Amplitude: ±2mm。 7. Time: X、Y、Z-way, Per 1 hour		n=5 C=0
5	High Temperature and Humidity Storage	1. Constant temperature cabinet 2. 70℃, humidity 90%~95, 3. Check consistency after 500 hours' storage	10 samples during 0~500μg/m <sup>3</sup>  0~100μg/m <sup>3</sup>	n=10 C=0
6	Cold Storage	1. Constant temperature cabinet 2. -30℃, humidity 90%~95, 3. Check consistency after 500 hours' storage	Maximum Error≤±10μg/m <sup>3</sup>  100~500μg/m <sup>3</sup>	n=10 C=0
7	Variation of Power Supply	4. 10 m <sup>2</sup> closed Lab,, 20℃, humidity 50%, particle generator and air cleaner 5. Power varies as the cycles of 4.5V to 5.5V ,then 5.5V to 4.5V with the pace of 0.1V/min for 2 hours. 6. Check consistency during Variation	Maximum Error≤±10%  FAN does not screeched	n=5 C=0
8	Power On-Off Cycle	1. 10 m <sup>2</sup> closed Lab,, 20℃, humidity 50%, particle generator and air cleaner 2. DC 5V power supply, keep On- Off frequency 0.5Hz for 72 hours and check consistency		n=10 C=0
9	Sleep Set On-Off Cycle	1. 10 m <sup>2</sup> closed Lab,, 20℃, humidity 50%, particle generator and air cleaner 2. DC 5V power supply, keep Sleep		n=10 C=0

<b>PLANTOWER</b> 攀藤科技	<b>PMS5003IB Datasheet</b>	DOCUMENT No	PTQ3011-2018
		Version	V1.0
		Date	2019-2-20

		Set Pin High-Low frequency 0.5Hz for 72 hours and check consistency		
10	Laser On-Off Cycle	1. 10 m <sup>2</sup> closed Lab,, 20°C, humidity 50%, particle generator and air cleaner 2. keep laser On-Off frequency 50Hz for 240 hours and check consistency		n=10 C=0
11	Salt Spray	5% industrial salt water, hydrolysis spray 100 hours, clean with purified water and store for 48 hours	No rust and discoloration of metal parts	n=1 C=0

## 10. Part Number Definition

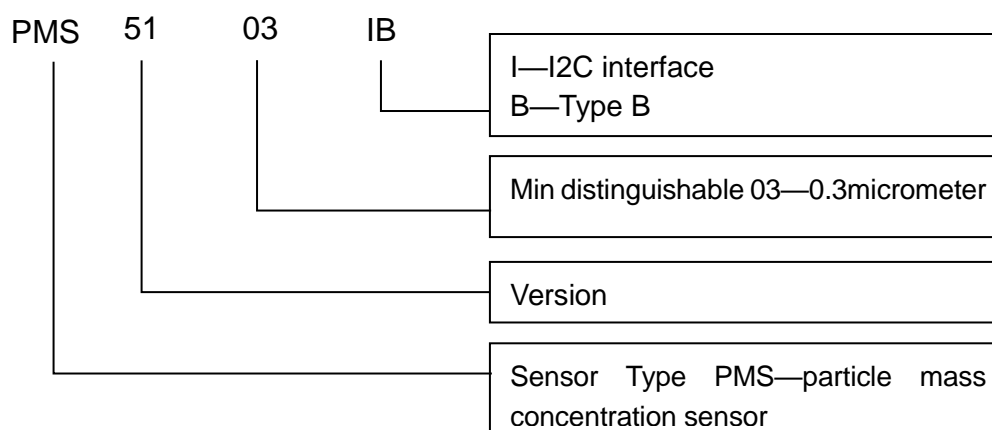

<b>PLANTOWER</b> 攀藤科技	<b>PMS5003IB Datasheet</b>	DOCUMENT No	PTQ3011-2018
		Version	V1.0
		Date	2019-2-20

### 11. Physical Size

(Unit:mm)

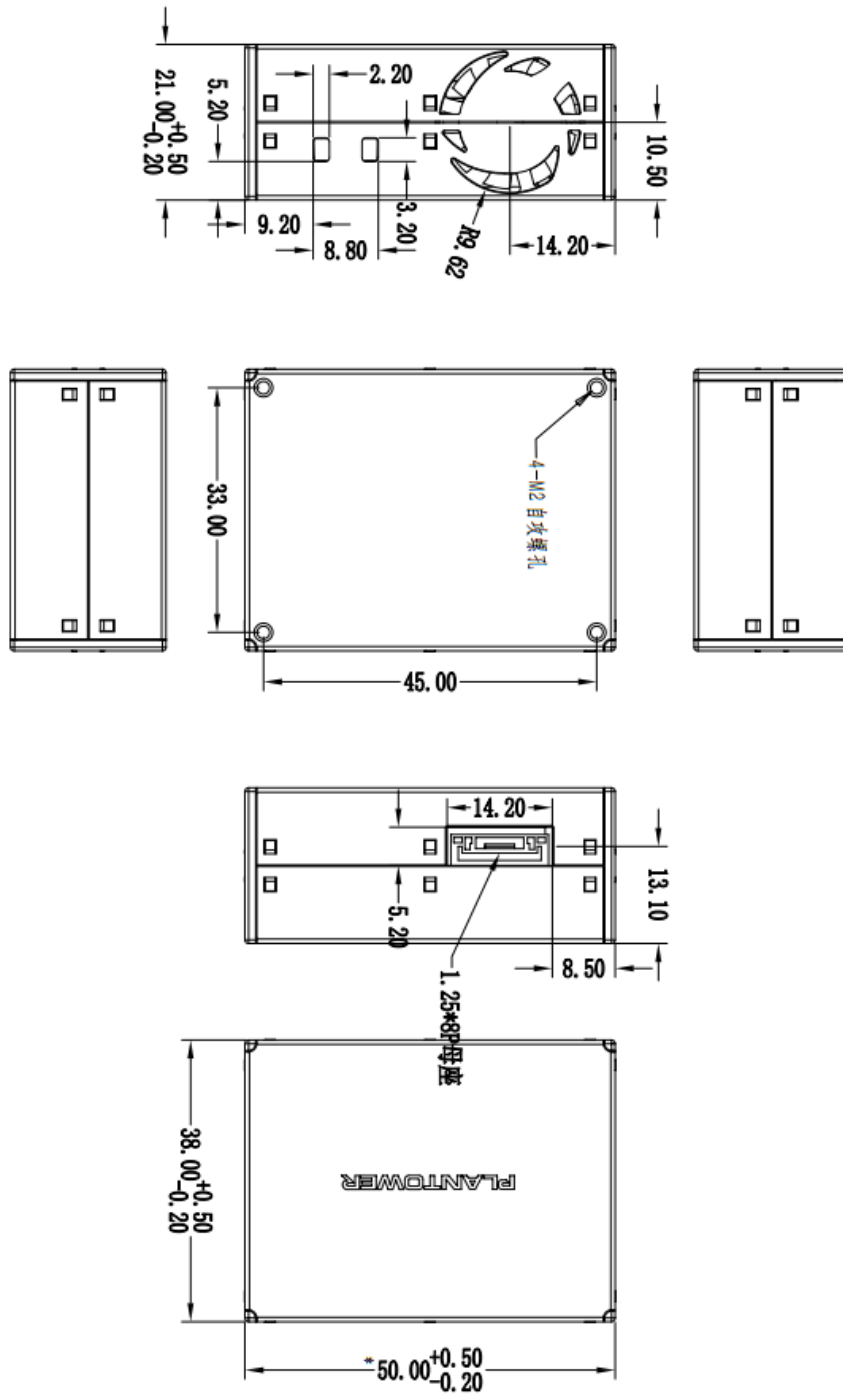

<b>PLANTOWER</b> 攀藤科技	<b>PMS5003IB Datasheet</b>	DOCUMENT No	PTQ3011-2018
		Version	V1.0
		Date	2019-2-20

## 12. Installation Attentions

- 1) Metal shell is connected to the GND so be careful not to let it shorted with the other parts of circuit except GND.
- 2) The best way of install is making the plane of inlet and outlet closely to the plane of the host. Or some shield should be placed between inlet and outlet in order to prevent the air flow from inner loop.
- 3) The blowhole in the shell of the host should not be smaller than the inlet.
- 4) The sensor should not be installed in the air flow way of the air cleaner or should be shielded by some structure.
- 5) The sensor should be installed at least 20cm higher than the grand in order to prevent it from blocking by the flock dust.
- 6) When the sensor is used to outdoor fixed equipment, the equipment should be completed for the protection of sandstorm,rain,snow,etc.
- 7) Do not break up the sensor.

## 13. Other Attentions

- 1) Only the consistency of all the PM sensors of PLANTOWER is promised and ensured. And the sensor should not be checked with any third party equipment.
- 2) The sensor is usually used in the common indoor environment. So some protection must be added if using in the conditions as followed:
  - a) The time of concentration  $\geq 300\mu\text{g}/\text{m}^3$  is longer than 50% of the whole year or concentration  $\geq 500\mu\text{g}/\text{m}^3$  is longer than 20% of the whole year.
  - b) Kitchen
  - c) Water mist condition such as bathroom or hot spring.

<b>PLANTOWER</b> 攀藤科技	<b>PMS5003IB Datasheet</b>	DOCUMENT No	PTQ3011-2018
		Version	V1.0
		Date	2019-2-20

d) Outdoor

#### 14. Appendix A: PMS5103I Protocol

1) 100K sps, Standard NXP EEPROM Protocol. Data are stored in the registers.

##### 2) Timing Sequence

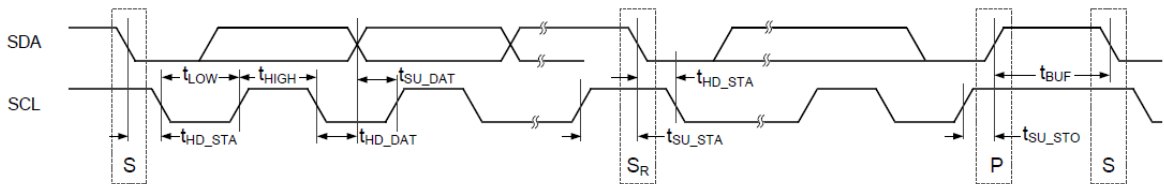

Parameter	t <sub>HD_STA</sub>	t <sub>LOW</sub>	t <sub>HIGH</sub>	t <sub>HD_DAT</sub>	t <sub>SU_DAT</sub>	t <sub>SU_STA</sub>	t <sub>SU_STO</sub>	t <sub>BUF</sub>
Min.	4.0	4.7	4.0	5.0	250	4.7	4.0	4.7
Unit	μs	μs	μs	μs	ns	μs	μs	μs

##### 3) Command Sequence

###### 3.1 Master reads from slave(sensor) continuously

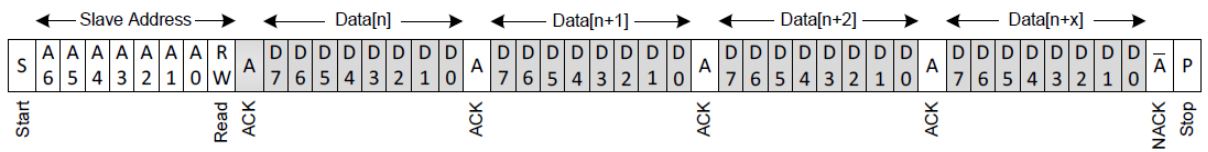

Note: white- Master, gray- Slave

###### 3.2 Master reads from slave at the appointed register.

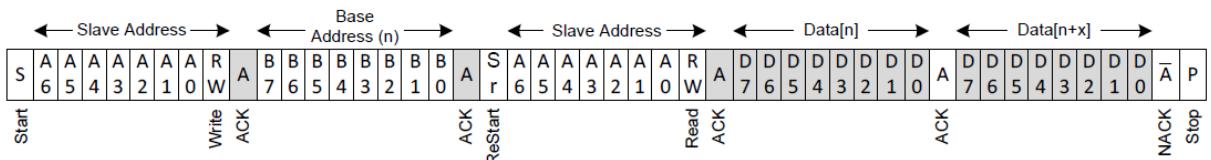

Note: white- Master, gray- Slave



<b>PLANTOWER</b> 攀藤科技	<b>PMS5003IB Datasheet</b>	DOCUMENT No	PTQ3011-2018
		Version	V1.0
		Date	2019-2-20

4) I2C Slave Address: 0x12

5) Data Registers

Register	Definition	Data	
0x00	Start character 1	0x42	
0x01	Start character2	0x4d	
0x02	Frame length high 8 bits	.....	Frame length=2x13+2(data+check bytes)
0x03	Frame length low 8 bits	.....	
0x04	Data 1 high 8 bits	.....	Data1 refers to PM1.0 concentration unit $\mu\text{g}/\text{m}^3$ ( CF=1 , standard particle ) *
0x05	Data 1 low 8 bits	.....	
0x06	Data2 high 8 bits	.....	Data2 refers to PM2.5 concentration unit $\mu\text{g}/\text{m}^3$ ( CF=1 , standard particle )
0x07	Data2 low 8 bits	.....	
0x08	Data3 high 8 bits	.....	Data3 refers to PM10 concentration unit $\mu\text{g}/\text{m}^3$ (CF=1, standard particle)
0x09	Data3 low 8 bits	.....	
0x0A	Data4 high 8 bits	.....	Data4 refers to PM1.0 concentration unit * $\mu\text{g}/\text{m}^3$ ( under atmospheric environment )
0x0B	Data4 low 8 bits	.....	
0x0C	Data5 high 8 bits	.....	Data 5 refers to PM2.5 concentration unit $\mu\text{g}/\text{m}^3$ ( under atmospheric environment )
0x0D	Data5 low 8 bits	.....	
0x0E	Data6 high 8 bits	.....	Data 6 refers to concentration unit (under atmospheric environment) $\mu$ g/m3
0x0F	Data6 low 8 bits	.....	

<b>PLANTOWER</b> 攀藤科技	<b>PMS5003IB Datasheet</b>	DOCUMENT No	PTQ3011-2018
		Version	V1.0
		Date	2019-2-20

0x10	Data7 high 8 bits	.....	Data 7 indicates the number of particles with diameter beyond 0.3 um in 0.1 L of air.
0x11	Data7 low 8 bits	.....	
0x12	Data8 high 8 bits	.....	Data 8 indicates the number of particles with diameter beyond 0.5 um in 0.1 L of air.
0x13	Data8 low 8 bits	.....	
0x14	Data9 high 8 bits	.....	Data 9 indicates the number of particles with diameter beyond 1.0 um in 0.1 L of air.
0x15	Data9 low 8 bits	.....	
0x16	Data10 high 8 bits	.....	Data10 indicates the number of particles with diameter beyond 2.5 um in 0.1 L of air.
0x17	Data10 low 8 bits	.....	
0x18	Data11 high 8 bits	.....	Data11 indicates the number of particles with diameter beyond 5.0 um in 0.1 L of air.
0x19	Data11 low 8 bits	.....	
0x1A	Data12 high 8 bits	.....	Data12 indicates the number of particles with diameter beyond 10 um in 0.1 L of air.
0x1B	Data12 low 8 bits	.....	
0x1C	Version Code	.....	0xA2
0x1D	Error Code *	.....	
0x1E	Data and check high 8 bits	.....	Check code=Start character 1+ Start character2+.....+data 13 Low 8 bits
0x1F	Data and check low 8 bits	.....	

Note1: CF=1 should be used in the factory environment

Note2: Definition of Error Code

<b>PLANTOWER</b> 攀藤科技	<b>PMS5003IB Datasheet</b>	DOCUMENT No	PTQ3011-2018
		Version	V1.0
		Date	2019-2-20

Bit7	Bit6	Bit5	Bit4	Bit3	Bit2	Bit1	Bit0
X	X	X	X	Stop warning: fan stop for 12 seconds	X	X	X

Stop warning (bit3): if the fan speeds lower than 200RPM means the fan should stopped. If the fan stopped for 12 seconds this bit would be set.